

Approval body for construction products  
and types of construction

Bautechnisches Prüfamt

An institution established by the Federal and  
Laender Governments



## European Technical Assessment

**ETA-06/0078**  
**of 21 January 2015**

English translation prepared by DIBt - Original version in German language

### General Part

Technical Assessment Body issuing the  
European Technical Assessment:

Deutsches Institut für Bautechnik

Trade name of the construction product

SORMAT MULTI-MONTI MMS

Product family  
to which the construction product belongs

Concrete screw for use in concrete

Manufacturer

Sormat Oy  
Harjutie 5  
21290 RUSKO  
FINNLAND

Manufacturing plant

Sormat Werk 5  
Sormat Plant 5

This European Technical Assessment  
contains

12 pages including 3 annexes which form an integral part  
of this assessment

This European Technical Assessment is  
issued in accordance with Regulation (EU)  
No 305/2011, on the basis of

Guideline for European technical approval of "Metal  
anchors for use in concrete", ETAG 001 Part 3: "Undercut  
anchors", April 2013,  
used as European Assessment Document (EAD)  
according to Article 66 Paragraph 3 of Regulation (EU)  
No 305/2011.

The European Technical Assessment is issued by the Technical Assessment Body in its official language. Translations of this European Technical Assessment in other languages shall fully correspond to the original issued document and shall be identified as such.

Communication of this European Technical Assessment, including transmission by electronic means, shall be in full. However, partial reproduction may only be made with the written consent of the issuing Technical Assessment Body. Any partial reproduction has to be identified as such.

This European Technical Assessment may be withdrawn by the issuing Technical Assessment Body, in particular pursuant to information by the Commission according to Article 25 Paragraph 3 of Regulation (EU) No 305/2011.

**Specific Part**

**1 Technical description of the product**

The Concrete Screw SORMAT MULTI-MONTI MMS is an anchor made of zinc plated steel of sizes 7.5, 10, 12, 14 and 16. The anchor is screwed into a predrilled cylindrical drill hole. The special thread of the anchor cuts an internal thread into the member while setting. The anchorage is characterised by mechanical interlock in the special thread.

The product description is given in Annex A.

**2 Specification of the intended use in accordance with the applicable European Assessment Document**

The performances given in Section 3 are only valid if the anchor is used in compliance with the specifications and conditions given in Annex B.

The verifications and assessment methods on which this European Technical Assessment is based lead to the assumption of a working life of the anchor of at least 50 years. The indications given on the working life cannot be interpreted as a guarantee given by the producer, but are to be regarded only as a means for choosing the right products in relation to the expected economically reasonable working life of the works.

**3 Performance of the product and references to the methods used for its assessment**

**3.1 Mechanical resistance and stability (BWR 1)**

Essential characteristic	Performance
Characteristic resistance for tension and shear loads	See Annex C 1 and C 2
Displacements under tension and shear loads	See Annex C 1 and C 2

**3.2 Safety in case of fire (BWR 2)**

Essential characteristic	Performance
Reaction to fire	Anchorage satisfy requirements for Class A1
Resistance to fire	See Annex C 3 and C 4

**3.3 Hygiene, health and the environment (BWR 3)**

Not applicable.

**3.4 Safety in use (BWR 4)**

The essential characteristics regarding Safety in use are included under the Basic Works Requirement Mechanical resistance and stability.

**3.5 Protection against noise (BWR 5)**

Not applicable.

**3.6 Energy economy and heat retention (BWR 6)**

Not applicable.

English translation prepared by DIBt

**3.7 Sustainable use of natural resources (BWR 7)**

The sustainable use of natural resources was not investigated.

**3.8 General aspects**

The verification of durability is part of testing the essential characteristics. Durability is only ensured if the specifications of intended use according to Annex B are taken into account.

**4 Assessment and verification of constancy of performance (AVCP) system applied, with reference to its legal base**

According to Decision of the Commission of 24 June 1996 (96/582/EC) (OJ L 254 of 08.10.96 p. 62-65), the system of assessment and verification of constancy of performance (see Annex V and Article 65 Paragraph 2 to Regulation (EU) No 305/2011) given in the following table applies.

Product	Intended use(s)	Level or class	System
Metal anchors for use in concrete (heavy-duty type)	For fixing and/or supporting concrete structural elements or heavy units such as cladding and suspended ceilings	—	1

**5 Technical details necessary for the implementation of the AVCP system, as provided for in the applicable European Assessment Document**

Technical details necessary for the implementation of the AVCP system are laid down in the control plan deposited at Deutsches Institut für Bautechnik.

Issued in Berlin on 21 January 2015 by Deutsches Institut für Bautechnik

Andreas Kummerow  
p.p. Head of Department

*beglaubigt:*  
Baderschneider

## Installed condition

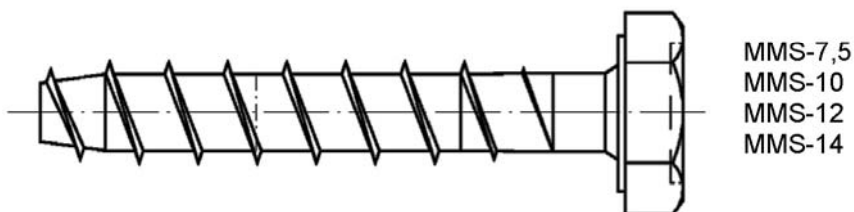
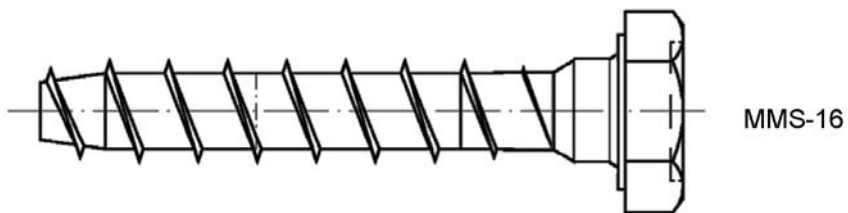
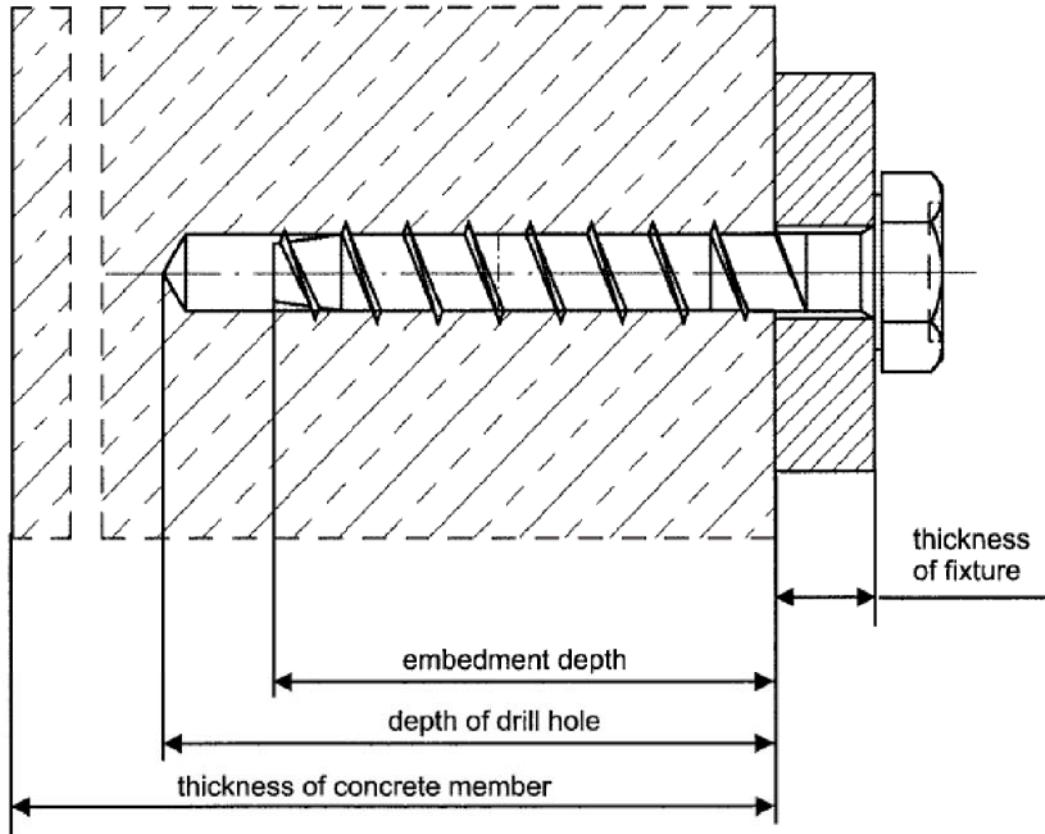

### SORMAT MULTI-MONTI MMS

Product description  
Product,  
Installed condition

Annex A 1

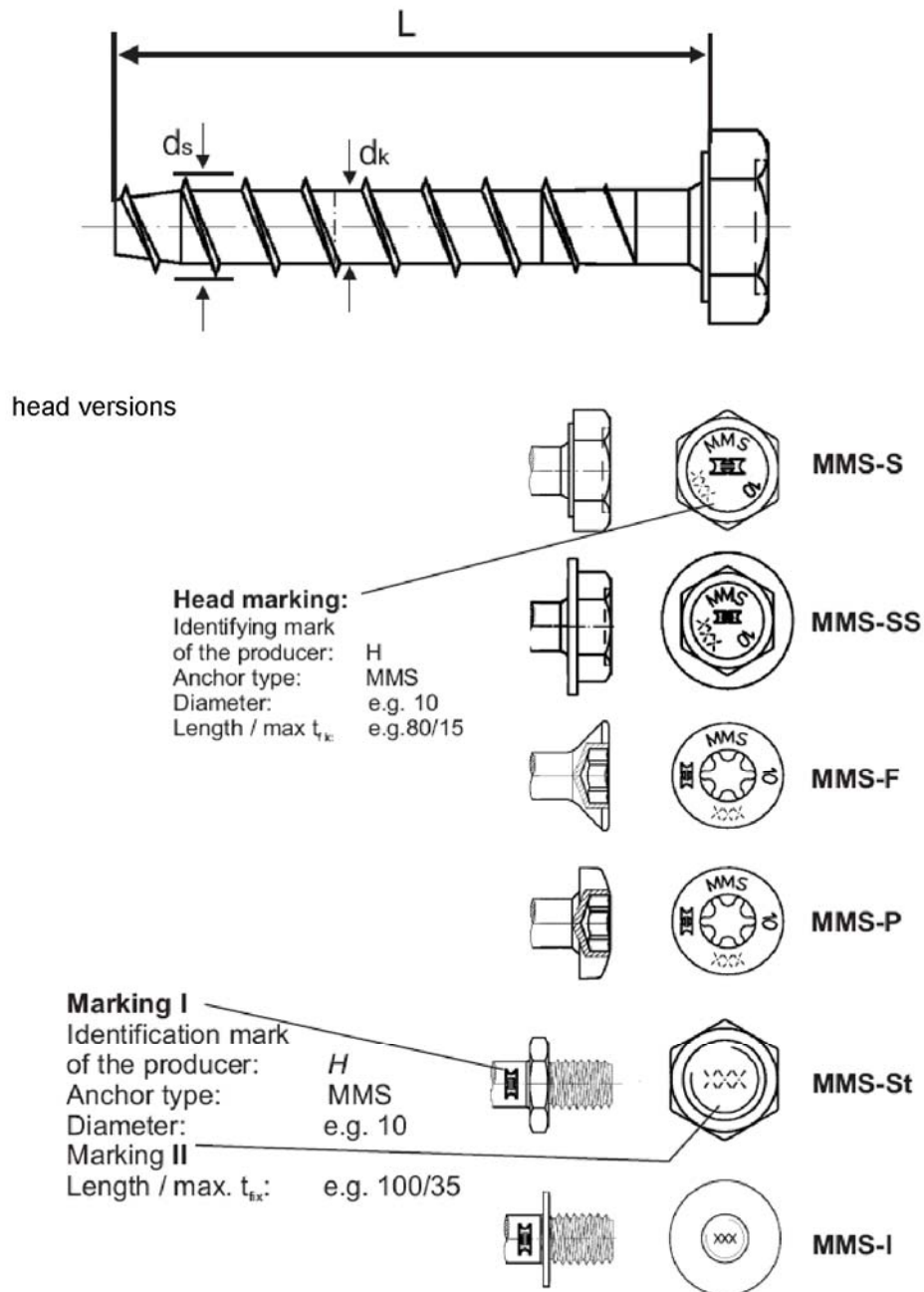

Table A1: Dimensions and Materials

Anchor sizes			MMS-7,5	MMS-10	MMS-12	MMS-14	MMS-16
Length	$L \geq$	[mm]	60	70	80	100	120
Length	$L \leq$	[mm]	200	200	400	400	400
Bolt diameter	$d_k$	[mm]	5,7	7,6	9,4	11,3	13,3
Thread diameter	$d_s$	[mm]	7,5	10,1	12,0	14,3	16,7
Material	galvanised steel acc. to EN 10263-4:2001						

## SORMAT MULTI-MONTI MMS

Product description  
Head Versions,  
dimensions and materials

Annex A 2

## Specifications of intended use

### Anchorage subject to:

- Static and quasi-static loads: all sizes.
- Fire exposure: all sizes.

### Base Materials:

- Reinforced or unreinforced normal weight concrete according to EN 206-1:2000.
- Strength classes C20/25 to C50/60 according to EN 206-1:2000.
- Non-cracked and cracked concrete: all sizes.

### Use conditions (Environmental conditions):

- Structures subject to dry internal conditions.

### Design:

- Anchorages are designed under the responsibility of an engineer experienced in anchorages and concrete work.
- Verifiable calculation notes and drawings are prepared taking account of the loads to be anchored. The position of the anchor is indicated on the design drawings (e. g. position of the anchor relative to reinforcement or to supports, etc.).
- Anchorages under static or quasi-static actions and under fire exposure are designed for design method A in accordance with:
  - ETAG 001, Annex C, Edition 2010
- In case of requirements for resistance of fire exposure it must be ensured that local spalling of the concrete cover does not occur.

### Installation:

- Hole drilling by hammer-drilling only.
- Anchor installation carried out by appropriately qualified personnel and under the supervision of the person responsible for technical matters of the site.
- In case of aborted hole: new drilling at a minimum distance away of twice the depth of the aborted hole or smaller distance if the aborted hole is filled with high strength mortar and if under shear or oblique tension load it is not the direction of the load application.
- The anchor may be used only once.
- The fixture is fully pressed on the concrete surface without intermediate layers.
- Further turning of the anchor is not easy.
- The head of the anchor is fully supported on the fixture and is not damaged.
- MMS-St: reach the required setting depth, securing the anchor against twisting.

## SORMAT MULTI-MONTI MMS

Intended Use  
Specifications

Annex B 1

**Table B1: Installation Parameters**

Anchor sizes		MMS-7,5	MMS-10	MMS-12	MMS-14	MMS-16
Nominal drill diameter	$d_0$ [mm]	6,0	8,0	10,0	12,0	14,0
Cutting diameter of the drill bit	$d_{cut} \leq$ [mm]	6,4	8,45	10,45	12,5	14,5
Depth of drill hole	$h_1 \geq$ [mm]	65	75	85	105	130
Embedment depth	$h_{nom} \geq$ [mm]	55	65	75	95	115
Diameter of clearance hole in the fixture	$d_f \leq$ [mm]	9,0	12,0	14,0	16,0	18,0
Recommended installation tool		Impact screw driver, max. power output $T_{max}$ according manufacturer information				
		100 Nm	250 Nm	250 Nm	350 Nm	500 Nm

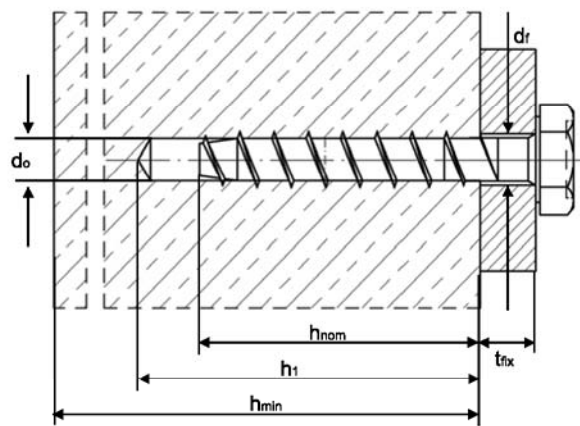

**Installation Instruction**

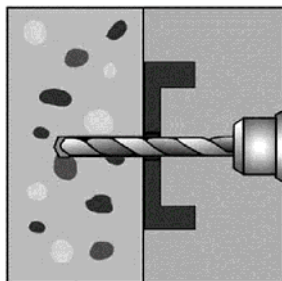

**Drilling**  
Drill diameter  $d_0$  and drilling depth  $h_1$  have to be kept

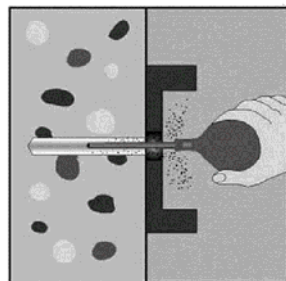

**Removal of drill dust**  
e.g. blowing

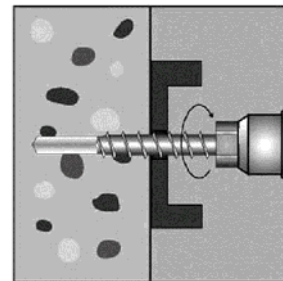

**Installation**  
e.g. by hand or with impact screw driver

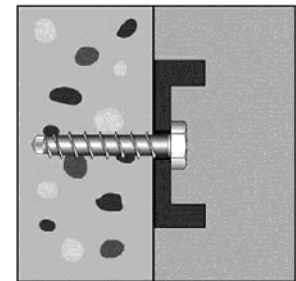

**Complete verification:** head supported to fixture and embedment depth  $h_{nom}$

**Table B2: Minimum thickness of concrete member, minimum spacing and minimum edge distances of anchor**

Anchor sizes		MMS-7,5	MMS-10	MMS-12	MMS-14	MMS-16
min. thickness of concrete member	$h_{min}$ [mm]	100	115	125	150	180
<b>cracked and non-cracked concrete</b>						
min. spacing	$s_{min} =$ [mm]	40	50	60	90	100
min. edge distance	$c_{min} =$ [mm]	40	50	60	90	100

**SORMAT MULTI-MONTI MMS**

**Intended Use**

Installation Parameters, installation instruction, minimum thickness of concrete member, minimum spacing and minimum edge distance of anchor

**Annex B 2**



**Table C1: Characteristic Values under tension loads**

Anchor sizes			MMS-7,5	MMS-10	MMS-12	MMS-14	MMS-16
<b>Steel failure</b>							
Characteristic resistance	$N_{Rk,s}$	[kN]	19,4	16	25	30	43
Partial safety factor	$\gamma_{Ms}$	[-]	1,4				
<b>Pullout</b>							
Characteristic resistance in cracked concrete C 20/25	$N_{Rk,p}$	[kN]	5	9	12	20	30
Characteristic resistance in non-cracked concrete C 20/25	$N_{Rk,p}$	[kN]	7,5	12	16	30	40
Increasing factor for concrete	$\psi_c$	C 30/37	1,22				
		C 40/50	1,41				
		C 50/60	1,55				
Installation safety factor	$\gamma_2$	[-]	1,2				
<b>Concrete cone failure, splitting failure</b>							
Effective anchorage depth	$h_{ef}$	[mm]	40	47,5	54,5	71,5	87,5
Spacing	$s_{cr,N} = s_{cr}$	[mm]	3 $h_{ef}$				
Edge distance	$c_{cr,N} = c_{cr}$	[mm]	1,5 $h_{ef}$				
Installation safety factor	$\gamma_2$	[-]	1,2				

**Table C2: Displacements under tension loads**

Anchor sizes			MMS-7,5	MMS-10	MMS-12	MMS-14	MMS-16
Tension load in cracked concrete	N	[kN]	2,0	3,0	4,0	7,2	9,7
Displacements	$\delta_{N0}$	[mm]	0,1	0,1	0,2	0,3	0,4
	$\delta_{N\infty}$	[mm]	0,2	0,3	0,6	0,8	0,8
Tension load in non-cracked concrete	N	[kN]	3,0	4,0	5,3	10,1	13,7
Displacements	$\delta_{N0}$	[mm]	0,1	0,1	0,2	0,3	0,4
	$\delta_{N\infty}$	[mm]	0,2	0,3	0,6	0,8	0,8

**SORMAT MULTI-MONTI MMS**

**Performance**  
Characteristic values under tension loads  
Displacements under tension loads

**Annex C 1**

**Table C3: Characteristic Values under shear loads**

Anchor sizes		MMS-7,5	MMS-10	MMS-12	MMS-14	MMS-16
<b>Steel failure without lever arm</b>						
Characteristic resistance	$V_{Rk,s}$ [kN]	6,9	16	23	36	49
Partial safety factor	$\gamma_{Ms}$ [-]	1,5				
<b>Steel failure with lever arm</b>						
Characteristic resistance	$M_{Rk,s}^0$ [Nm]	19	38	71	132	217
Partial safety factor	$\gamma_{Ms}$ [-]	1,5				
<b>Concrete pryout failure</b>						
Factor in equation 5.6 of ETAG 001, Annex C Section 5.2.3.3	k	1,0	2,0			
Installation safety factor	$\gamma_2$ [-]	1,0				
<b>Concrete edge failure</b>						
Effective length of the anchor under shear loading	$l_f$ [mm]	40	47,5	54,5	71,5	87,5
Effective diameter of the anchor	$d_{nom}$ [mm]	6	8	10	12	14
Installation safety factor	$\gamma_2$ [-]	1,0				

**Table C4: Displacements under shear loads**

Anchor sizes		MMS-7,5	MMS-10	MMS-12	MMS-14	MMS-16
Shear load in cracked and non-cracked concrete	V [kN]	3,3	8,9	14,7	20,3	28,1
Displacements	$\delta_{v0}$ [mm]	0,8	3,0	3,0	3,0	4,5
	$\delta_{v\infty}$ [mm]	1,2	4,5	4,5	4,5	6,0

Information for design of anchorage under shear load:

In general, the conditions given in ETAG 001, Annex C, section 4.2.2.1 a) and section 4.2.2.2 b) are not fulfilled because the diameter of clearance hole in the fixture according to Table B1 is greater than the values given in Annex C Table 4.1 for the corresponding diameter of the anchor.

However for each specific anchor length the manufacturer may specify the thickness of fixture for which these conditions are fulfilled.

## SORMAT MULTI-MONTI MMS

**Performance**  
Characteristic values under shear loads  
Displacements under shear loads

**Annex C 2**

**Table C5: Characteristic values to tension loads under fire exposure in cracked and non-cracked concrete C20/25 to C50/60**

Anchor sizes			MMS-7,5	MMS-10	MMS-12	MMS-14	MMS-16	
<b>Steel failure</b>								
Characteristic resistance	R30	$N_{Rk,s,fi}$	[kN]	1,7	3,4	5,9	8,3	10,8
	R60			1,2	2,5	4,4	6,3	8,1
	R90			0,8	1,7	3,0	4,2	5,4
	R120			0,6	1,2	2,2	3,1	4,1
Characteristic resistance for MMS-St with metric stud	R30	$N_{Rk,s,fi}$	[kN]	1,7	1,8			
	R60			1,2	1,5			
	R90			0,8	1,1			
	R120			0,6	1,0			
<b>Pullout</b>								
Characteristic resistance in concrete C20/25 to C50/60	R30	$N^0_{Rk,p,fi}$	[kN]	1,3	2,3	3,0	5,0	7,5
	R60							
	R90							
	R120			1,0	1,8	2,4	4,0	6,0
<b>Concrete cone failure</b>								
Characteristic resistance in concrete C20/25 to C50/60	R30	$N_{Rk,c,fi}$	[kN]	1,8	2,8	3,9	7,8	12,9
	R60							
	R90							
	R120			1,5	2,2	3,2	6,2	10,3
Spacing	$s_{cr,N}$	[mm]	$4 \times h_{ef}$					
	$s_{min}$	[mm]	$s_{min}$ acc. to Annex B 2					
Edge distance	$c_{cr,N}$	[mm]	$2 \times h_{ef}$					
	$c_{min}$	[mm]	$c_{min} = 2 \times h_{ef}$ if fire attack is from more than on side, the edge distance of the anchor has to be bigger than 300 mm.					

**SORMAT MULTI-MONTI MMS**

**Performance**  
Characteristic values of tension load resistance under fire exposure

**Annex C 3**

**Table C6: Characteristic values to shear loads under fire exposure in cracked and non-cracked concrete C20/25 to C50/60**

Anchor sizes			MMS-7,5	MMS-10	MMS-12	MMS-14	MMS-16	
<b>Steel failure without lever arm</b>								
Characteristic resistance	R30	$V_{Rk,s,fi}$	[kN]	1,7	3,4	5,9	8,3	10,8
	R60			1,2	2,5	4,4	6,3	8,1
	R90			0,8	1,7	3,0	4,2	5,4
	R120			0,6	1,2	2,2	3,1	4,1
<b>Steel failure with lever arm</b>								
Characteristic resistance	R30	$M^0_{Rk,s,fi}$	[Nm]	1,5	4,0	8,8	15,0	22,0
	R60			1,1	3,0	6,6	11,0	17,0
	R90			0,7	2,0	4,4	7,4	11,0
	R120			0,5	1,5	3,3	5,6	8,3
<b>Concrete pryout failure</b>								
In Equation (5.6) of ETAG 001, Annex C, 5.2.2.3 the k-factor 2,0 (1,0 for MMS-7,5) and the relevant values of $N^0_{Rk,c,fi}$ Table C5 have to be considered.								
<b>Concrete edge failure</b>								
The initial value $V^0_{Rk,c,fi}$ of the characteristic resistance on concrete C20/25 to C50/60 under fire exposure may be determined by:								
$V^0_{Rk,c,fi} = 0,25 \times V^0_{Rk,c}$ (R30, R60, R90)				$V^0_{Rk,c,fi} = 0,20 \times V^0_{Rk,c}$ (R120)				
With $V^0_{Rk,c}$ initial value of the characteristic resistance in cracked concrete C20/25 under normal temperature.								

**SORMAT MULTI-MONTI MMS**

**Performance**  
Characteristic values of shear load resistance under fire exposure

**Annex C 4**